

CAUTION - READ MANUAL & ALL NOTES BEFORE INSTALLING OR OPERATING CONTROL - SEE NOTE 1.
NO CIRCUIT CALIBRATION OR ADJUSTMENT EVER REQUIRED.

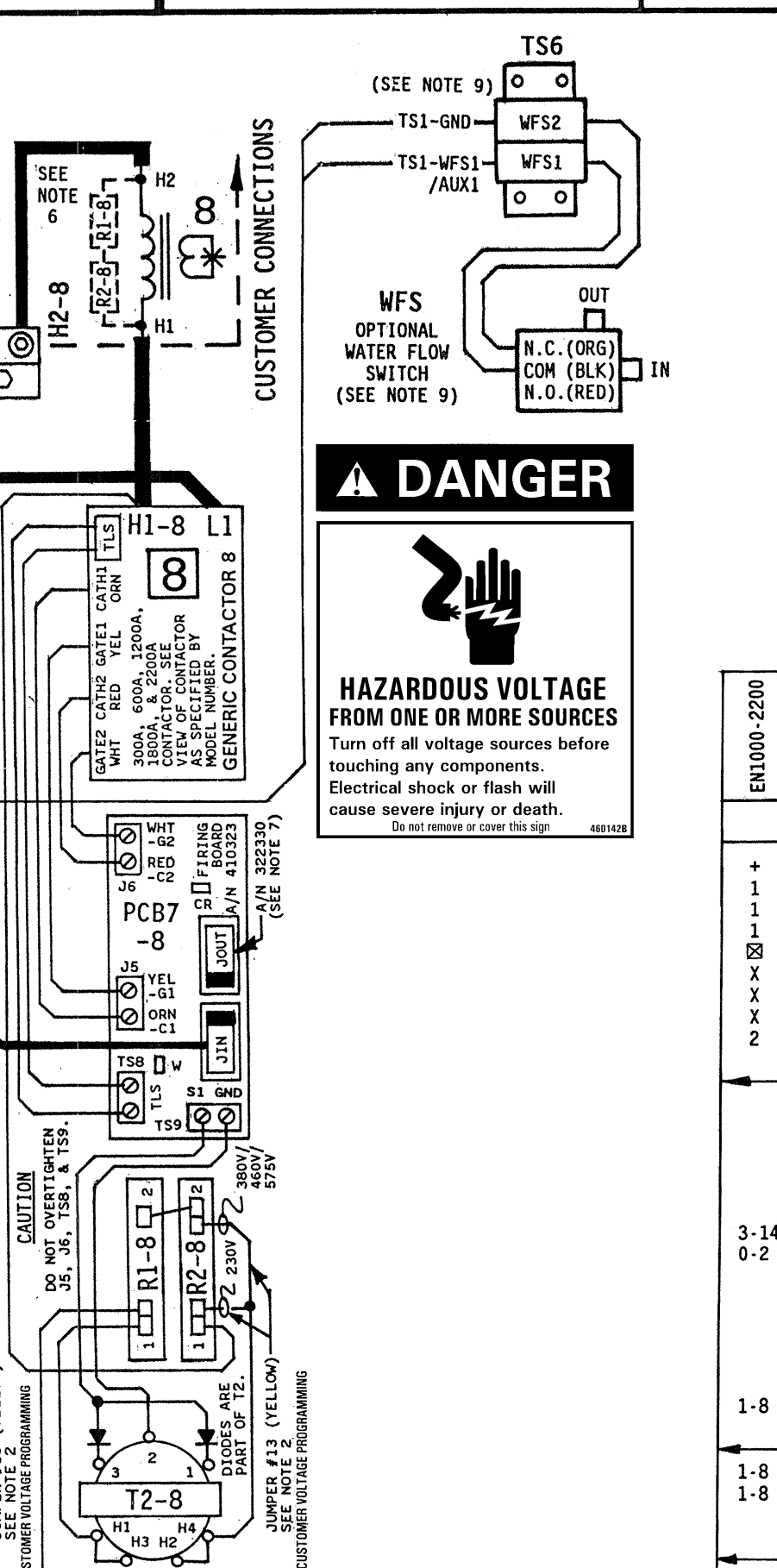
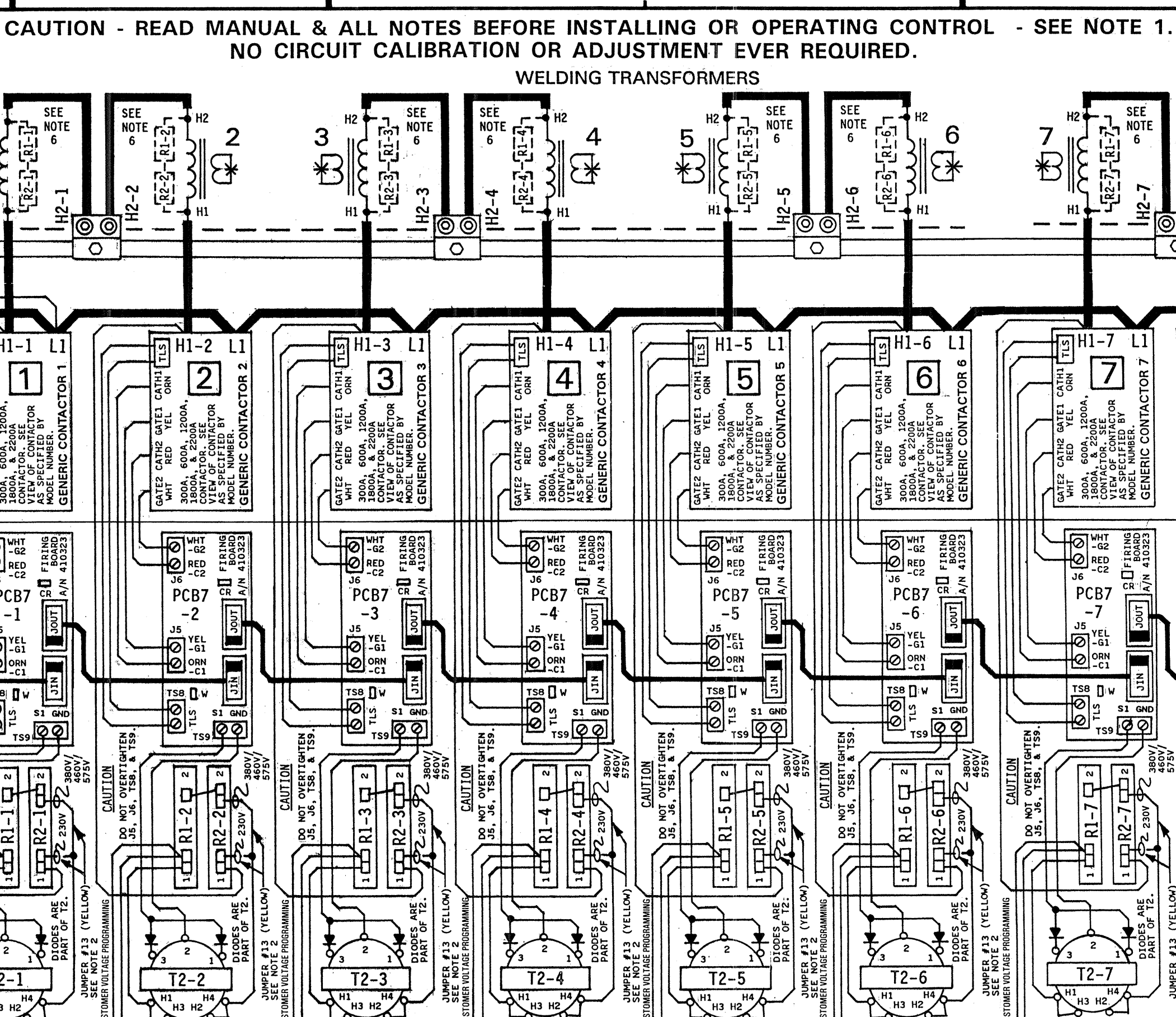
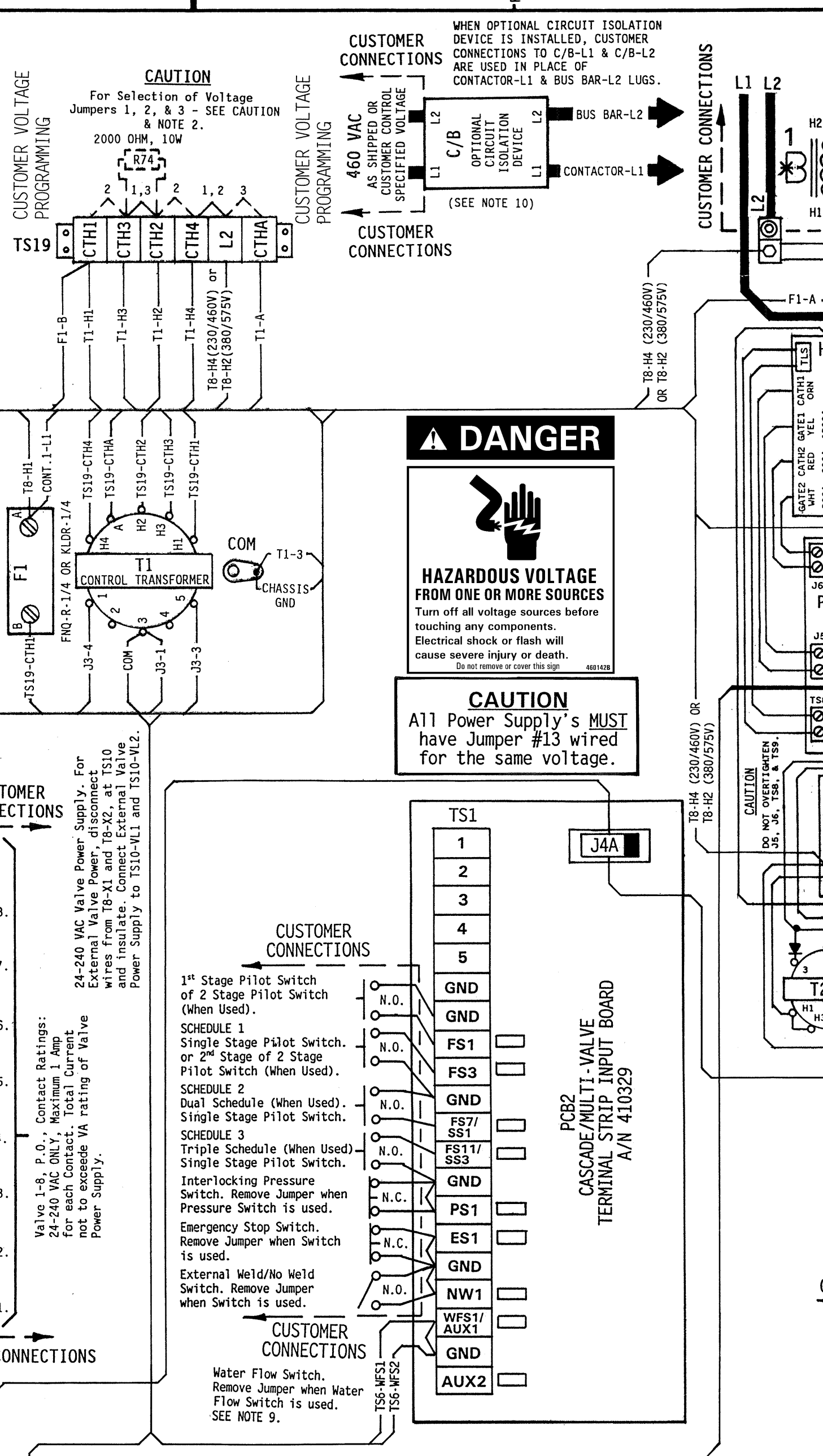
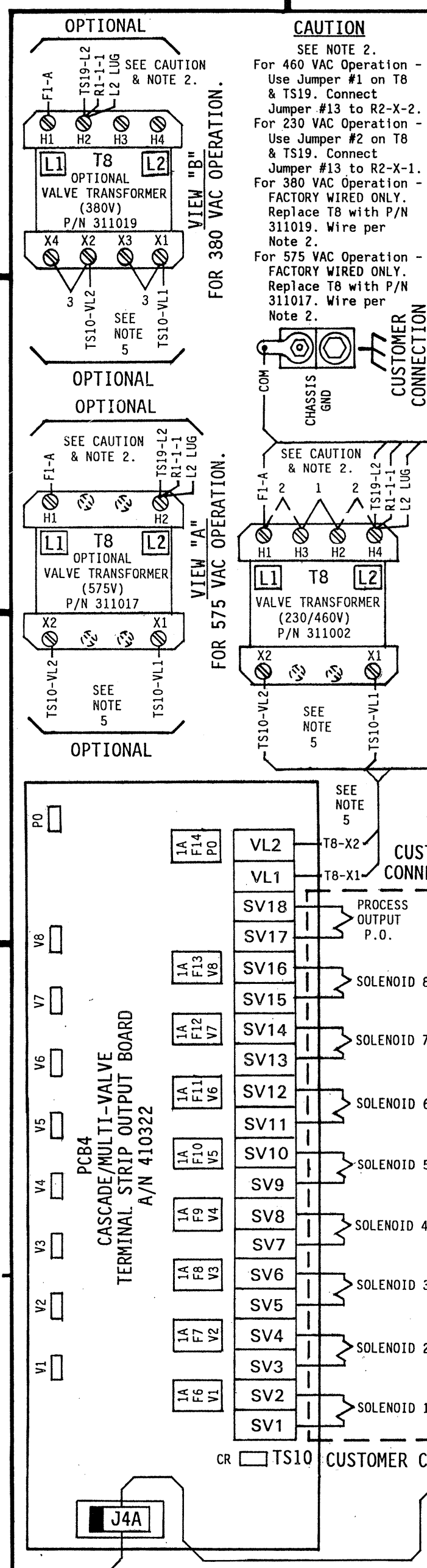

PARTS LIST - CONTROL SECTION

QTY	DESIG.	PART NO.	DESCRIPTION
1	PCB1	600558	Assem., Dial Plate, EN1000 Cascade, Consisting of:
1		600541-001	Assem. Switch, Front Panel Display Board
1		540284	Illustrated Panel, Dial Plate, EN1000 Cascade/Multi-Valve
1		515096	Display Window, Panel, Red Filter, Cont. & Valve, EN1000 Cascade
1		515104	Display Window, Panel, Red Filter, LED, EN1000 Cascade
1		410324	Assem., PCB, Contactor Weld & Valve Indicator Board, EN1000 Casc.

PARTS LIST - CONTACTOR SECTION

QTY	DESIG.	PART NO.	DESCRIPTION
1	TS6	335017	Terminal Strip, 2 Pin, 15A. (For WFS)
1	TS9	335024	Terminal Strip, 6 Pin, 20A
1	TS19	310001	Transformer, Control. (Part of 33 Harness)
1	T1	311002	Transformer, Valve, 150VA, 230/460V
1	T8	311017	Transformer, Valve, 150VA, 575V
1	T8	311019	Transformer, Valve, 150VA, 380/408/415V
1	T8	322342	Transformer, Valve, 250VA
1	T8	322343	Transformer, Valve, 500VA
1	(T8)	325149	Assem., Wire, Valve Transformer, 22 Ga., Black

ENTRON RS485 DRIVER BOARD DIP SWITCH SETTINGS

POSITION	ON	OFF
POSITION 4	ON	OFF
POSITION 3	ON	OFF
POSITION 2	OFF	ON
POSITION 1	OFF	ON

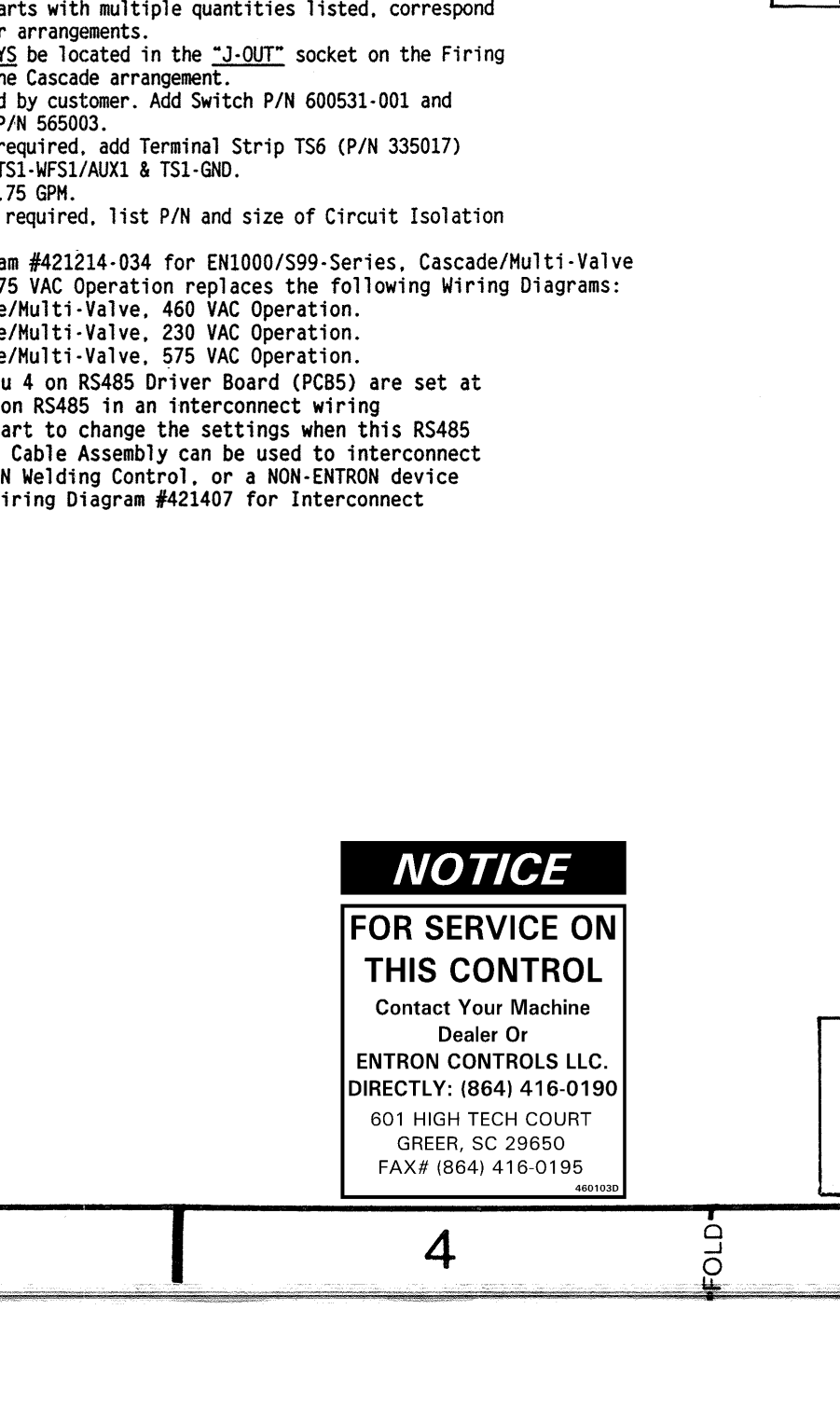
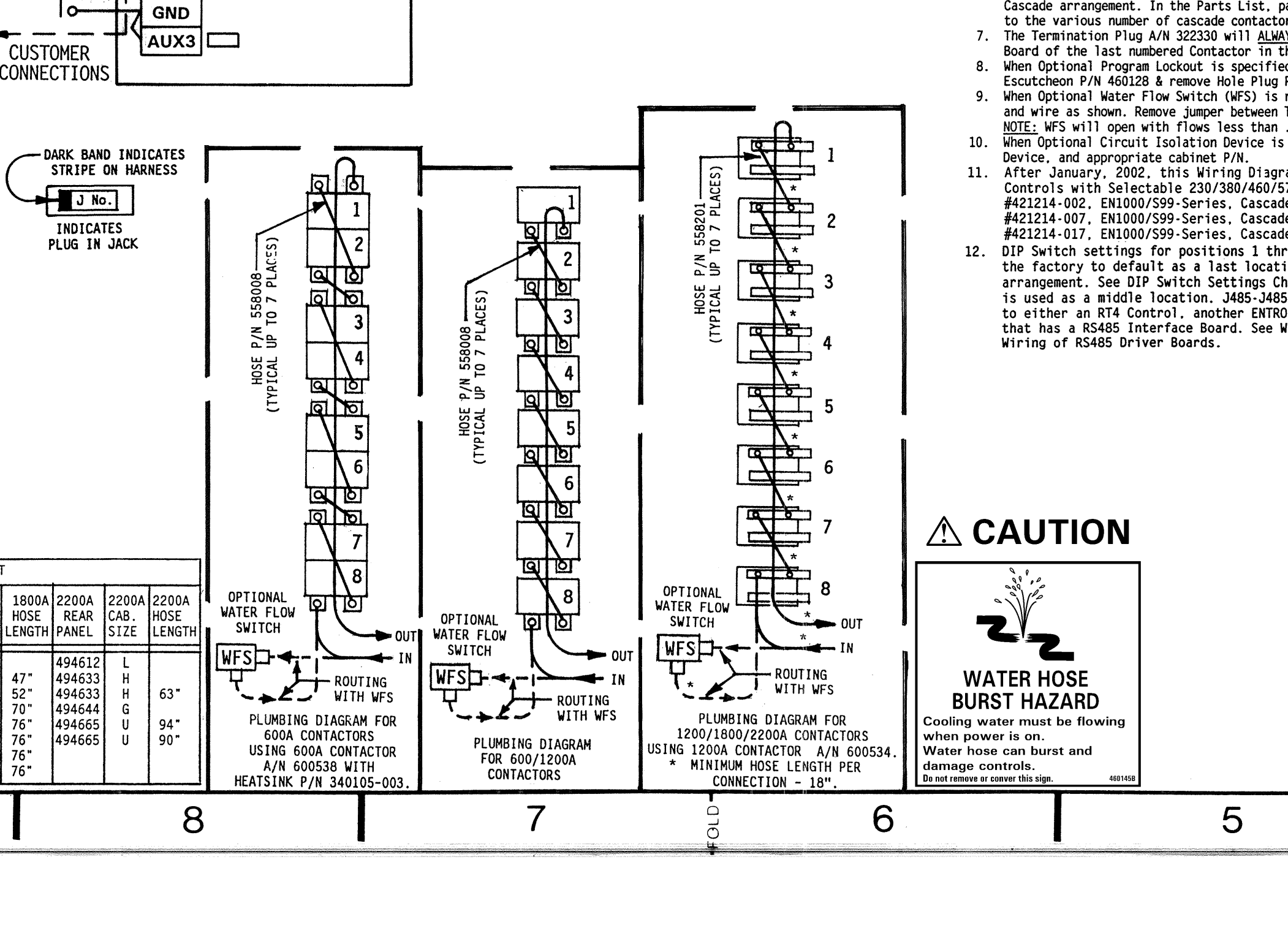
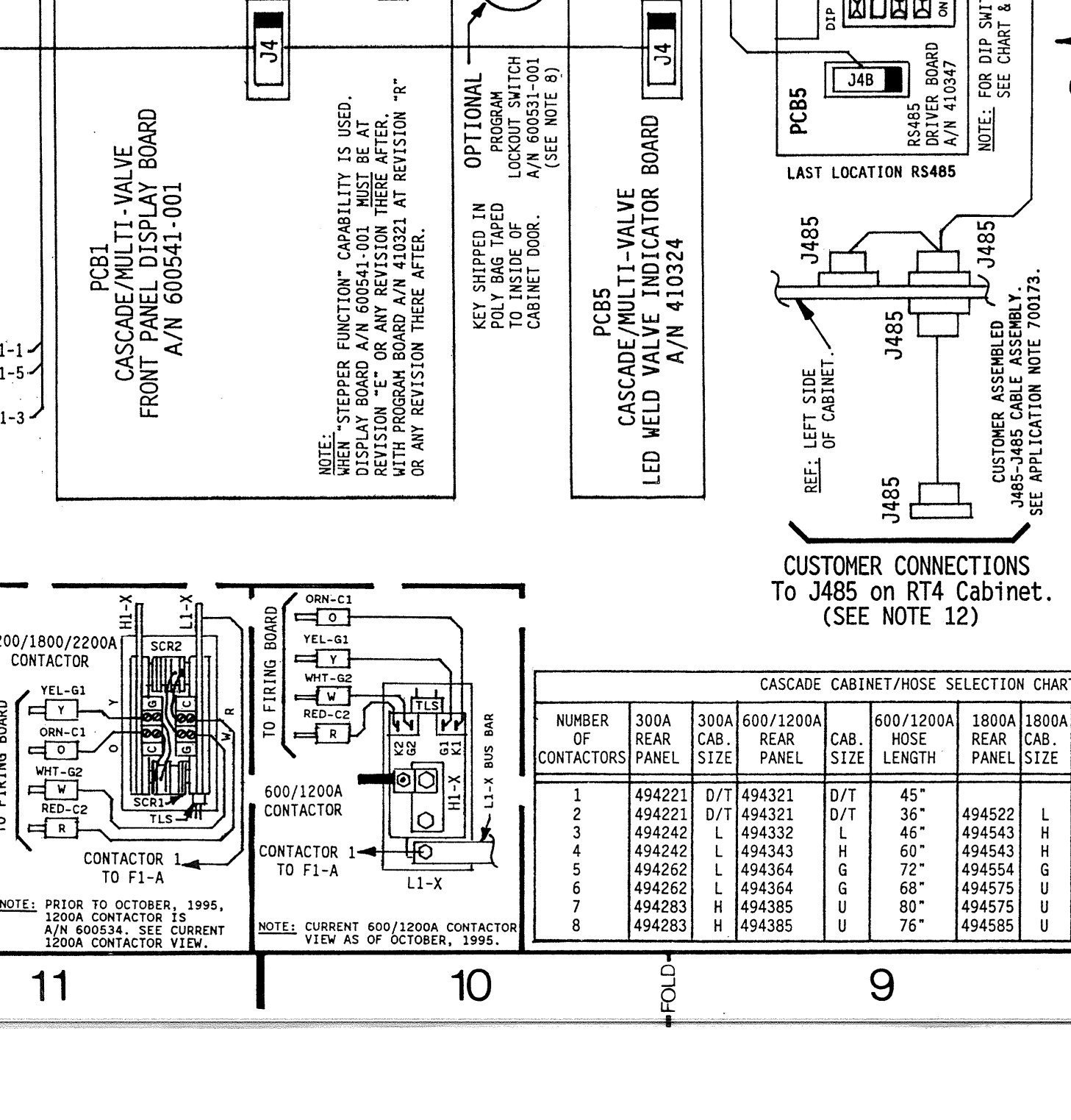
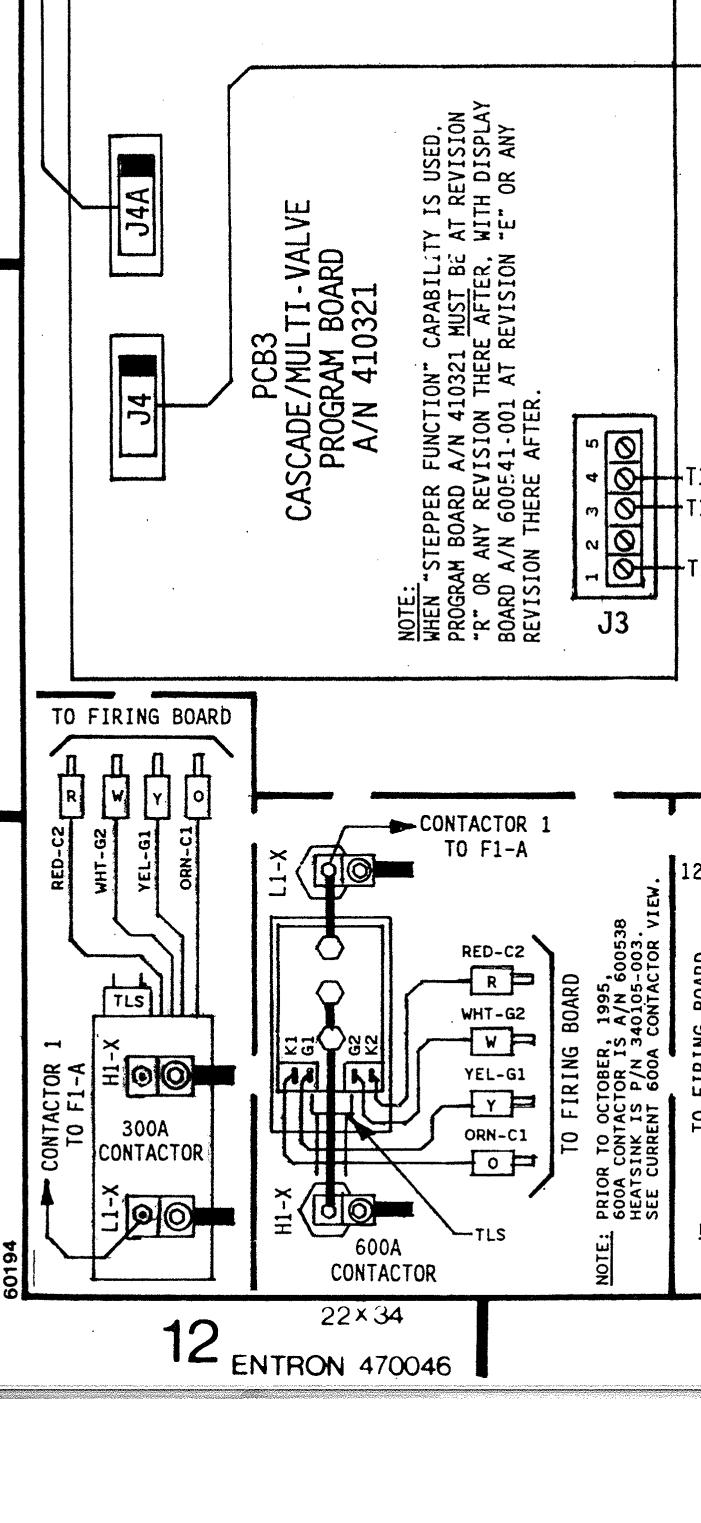

ENTRON CONTROLS INC.

CHANGED DRAWING NUMBER WAS 421214-042

REV	AUTH	DESCRIPTION	DATE	DRSN BY	CHK BY
		ORIGINAL RELEASE			

SCALE	DATE	DRAWN BY	CHK'D BY	APPROVED BY
	10/31/07	DPDH		

NOTICE FOR SERVICE ON THIS CONTROL
Contact Your Machine Dealer Or ENTRON CONTROLS, L.C. DIRECTLY: (864) 416-0190
601 HIGH TECH COURT
GREER, SC 29605
FAX: (864) 416-0195

CAUTION
Control Shipped in 460 VAC Operation unless otherwise specified.