

**NOTES:**

- It is recommended that control wiring (i.e.: initiation, pressure switch, etc.) be physically separated from the high voltage wiring (115 volts or higher).
- For 460 VAC Operation - Use Jumper #1 on T3 & T51. As shipped unless otherwise specified. For 230 VAC Operation - Use Jumper #2 on T3 & T51.
- For 575 VAC Operation - FACTORY WIRED ONLY. SEE VIEW "A". Replace T3 with P/N 311016. Wire per View "A". Use Jumper #1 between H2 & H3 on T51. Use Resistor R74 (2000 Ohm, 10 Watt) in place of Jumper #1 between CTH2 & CTH3 on T51. For 115 VAC or 380 VAC Operation - CONSULT FACTORY.
- For Single Stage Pilot Operation - Connect pilot switch to T51-F53 & T51-GND. No jumpers required across T51-F51 & T51-GND.
- For Two Stage Pilot Operation - Connect 1st stage pilot switch to T51-F51 & T51-GND. Connect 2nd stage pilot switch to T51-F53 & T51-GND.
- For DUAL COUNT/DUAL CURRENT (Dual Weld/Dual Heat) or TRIPLE COUNT/TRIPLE CURRENT (Triple Weld/Triple Heat) or External Schedule Selection. SEE MANUAL.
- EN1380-S (IGN) & EN1380-S (SCR): When used, connect customer provided Normally Closed (N.C.) Temperature Limit Switch (TLS) across T51-TLS1/AUX1 & T51-GND and remove jumper between T51-TLS1/AUX1 & T51-GND. EN1380-150S, EN1380-300S, & EN1380-600S: ENTRON supplies Temperature Limit Switch (TLS) P/N 300020 and provides connections to T51-TLS1/AUX1 & T51-GND. Jumper not required between T51-TLS1/AUX1 & T51-GND. NOTE: TLS Thyristor will open at temperatures greater than or equal to 150°F.
- When external valve power is supplied to the control. Remove and insulate leads T53-VL1 & T53-VL2 on the Terminal Strip Board (PCB2). (From T3-X1 & T3-X2). Connect external AC power supply (24-240 VAC) to T51-VL1 & T51-SV2/SV4/VL2. CAUTION: Do not overtighten T53.
- VALVE 3 OUTPUT USAGE: T51-SV5 & T51-SV6 (Valve 3) can be used for either a Valve output or a Process output. When T51-SV5 & T51-SV6 is used as a Valve output use Jumper "A" on T53. When T51-SV5 & T51-SV6 is used as a Process output use Jumper "B" on T53. CAUTION: Do not overtighten T53.
- Warnings: Use of Jumper "B" bypasses control relay contacts to allow a process output without an initiation. SEE MANUAL.
- Connect T51-L2/CTH4 to L2/H2 side of Welding Transformer Primary.
- When Optional Program Lockout is specified by customer, Dial Plate A/N 600648-001 replaces A/N 600648. Add Switch P/N 600531-001 & remove Hole Plug P/N 565003.
- EN1380-S (IGN) & EN1380-S (SCR): Remove all connections from previously existing firing circuits to L1, L2/H2, & H1 also ignitor leads of SCR Gate leads & SCR Cathode leads. All previously existing surge resistors or Rectifiers must be disconnected prior to installation of this control. CAUTION: On EN1380-S (SCR), Do not overtighten J5 & J6.
- For External SCR Contactor firing with SCHLATTER P/N S55.5, ES65.5, & ES130 Contactors. Do NOT make J5 & J6 connections as shown on PCB2. See EN1380-S (SCR) Contactor Wiring Diagram with SCHLATTER Contactors. Install Jumper on PCB2 Terminal Strip Board between J5-2 (Yellow) & J6-1 (Red). Make connections from J5-1 (Orange) & J6-2 (White) on PCB2 to SCHLATTER Contactor per correct External SCR Contactor Wiring Diagram.
- CAUTION: Do NOT set current control below 40% for 230 Volt Operation with Ignitron Tube Contactor. ABBREVIATED DESCRIPTION OF OPERATION FOR Typical Butt Welder, SE = 01: Close F53 to GND to begin Flash Weld. Open F53 to GND to begin a timed (in cycles) upset. Flash Percent Current, Upset Time, and Percent Current can be varied by changing Front Panel variables. Close F57 to GND to begin Annual 1. Open F57 to GND to begin a timed (in seconds) Annual 2. Annual 2 time ONLY can be affected by Heat and Cool Time (in cycles). Annual 1 Percent Current, Heat (in cycles), and Cool (in cycles) can all be affected by changing Front Panel variables. DESCRIPTION OF OPERATION FOR Typical Butt Welder, SE = 02: Momentary Close F53 to GND to begin Clump Weld. Connect Clamp Valve to SV1 & SV2. Connect Squeeze Valve to SV3 & SV4 (Clamp & Squeeze times are the same). If Annual is desired, see F57 operation above. See Manual for more information.

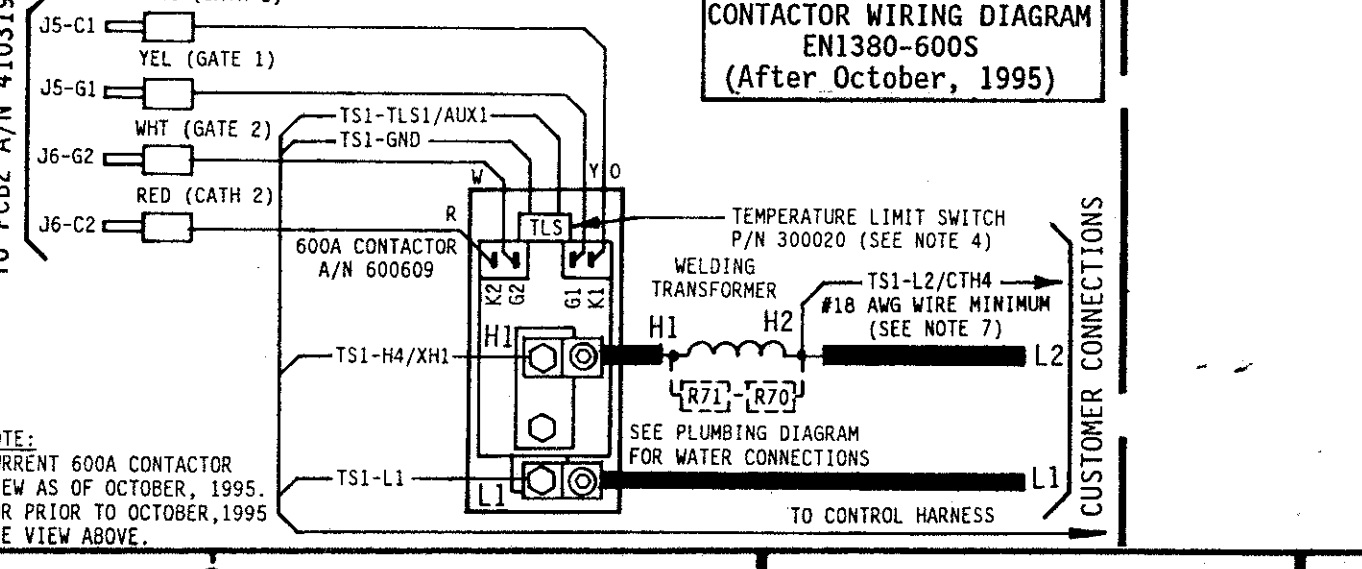
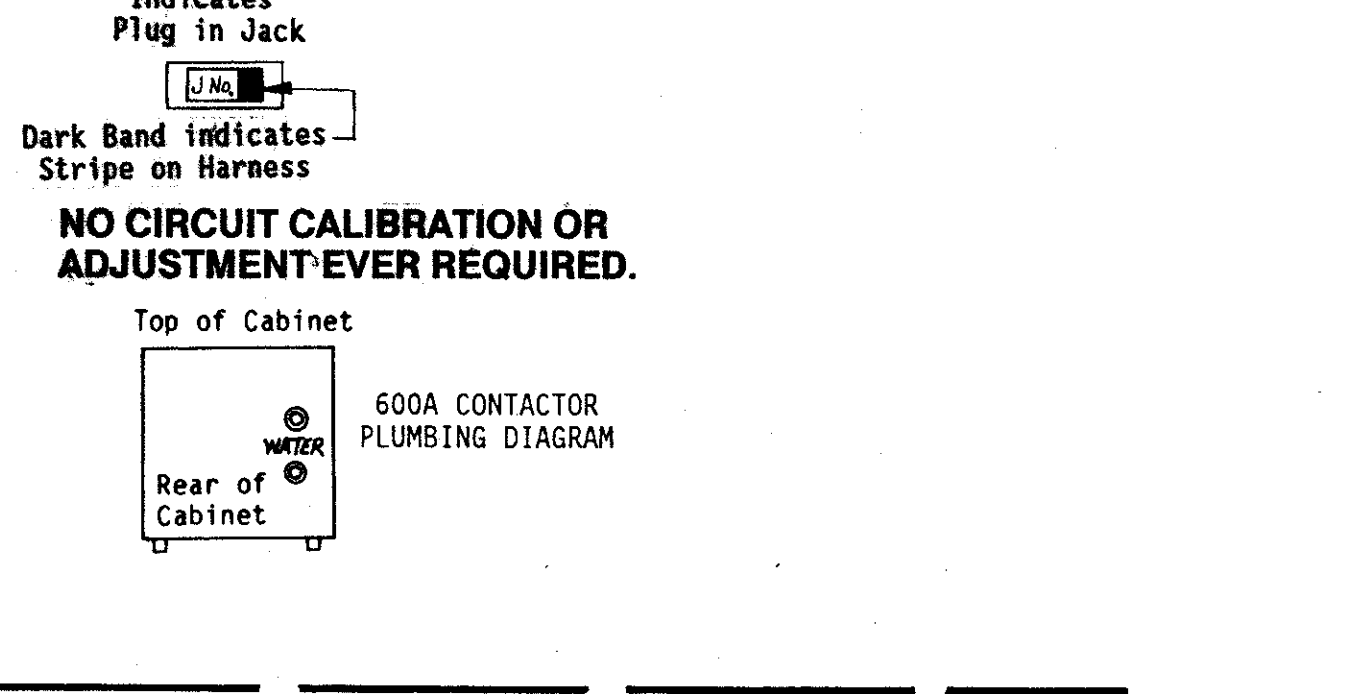
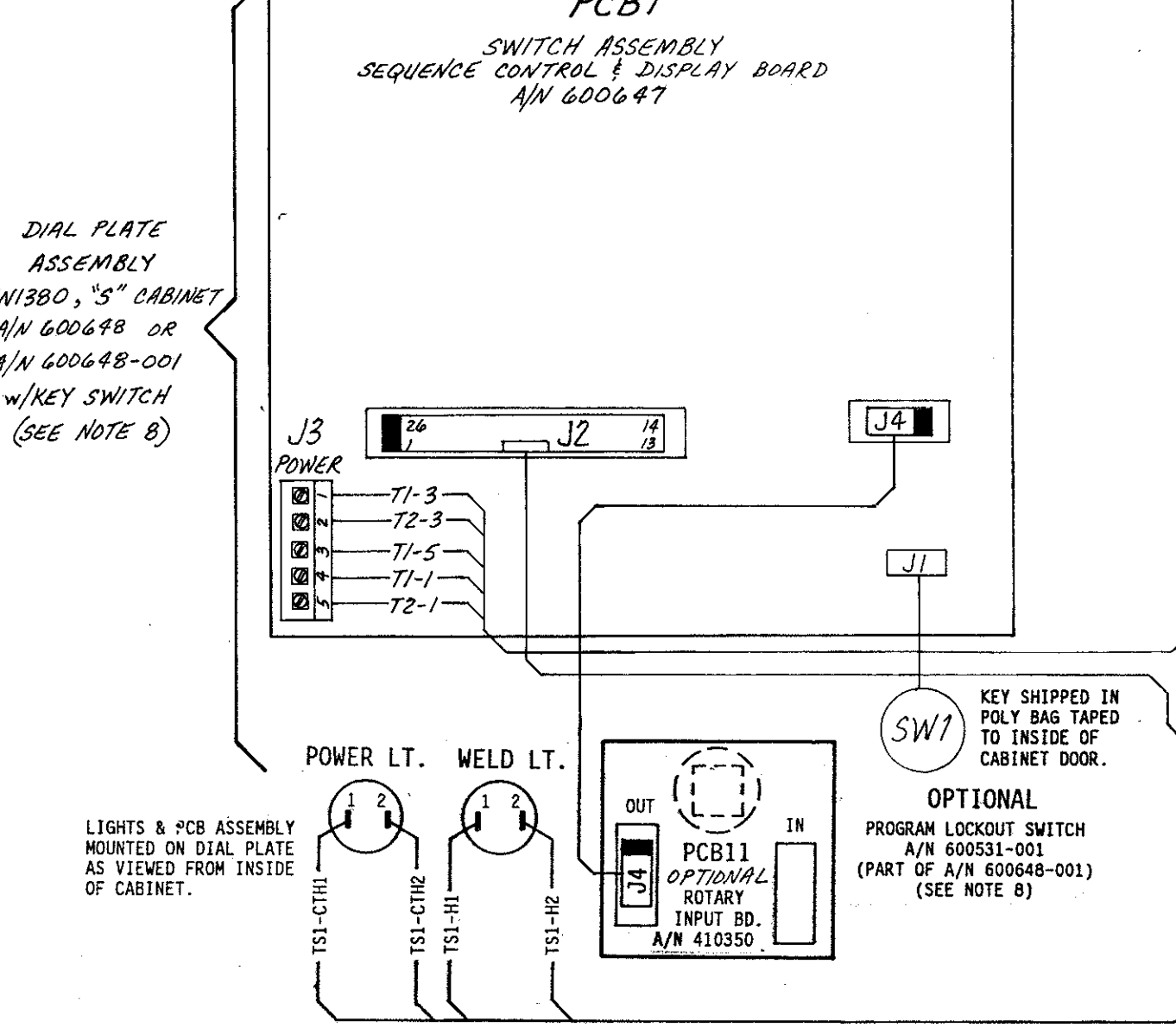

**FOR SERVICE ON THIS CONTROL CONTACT YOUR MACHINE DEALER**

**ENTRON CONTROLS INC. DIRECTLY: (630) 682-9600**  
485 EAST RANDY ROAD  
CAROL STREAM, IL 60188  
FAX # (630) 682-3374

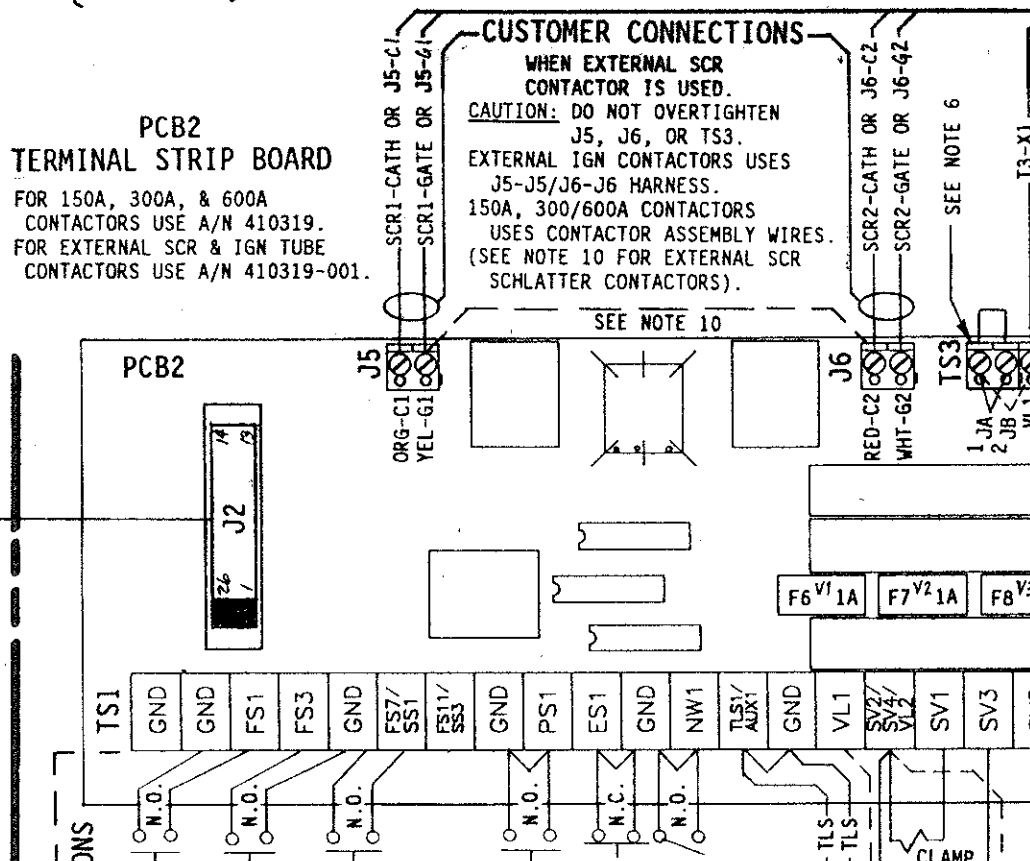
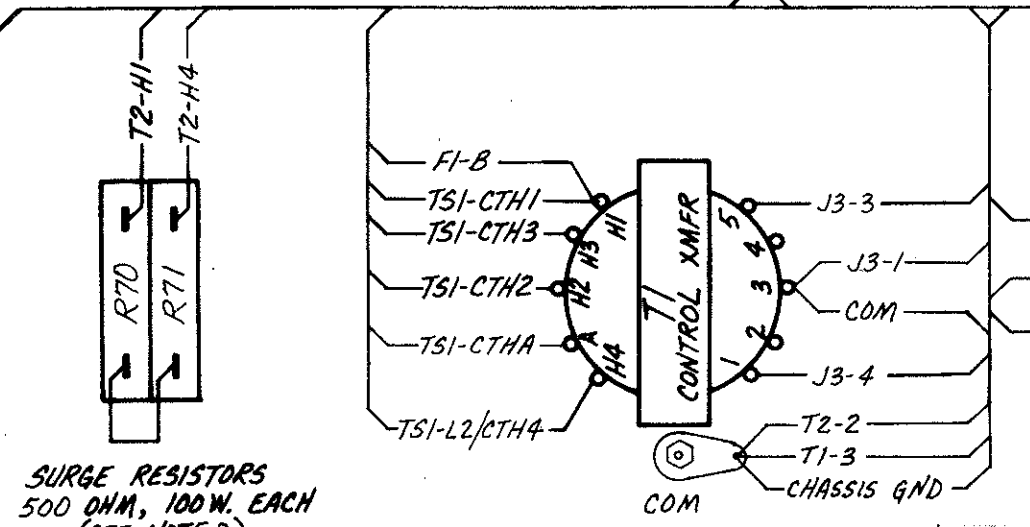
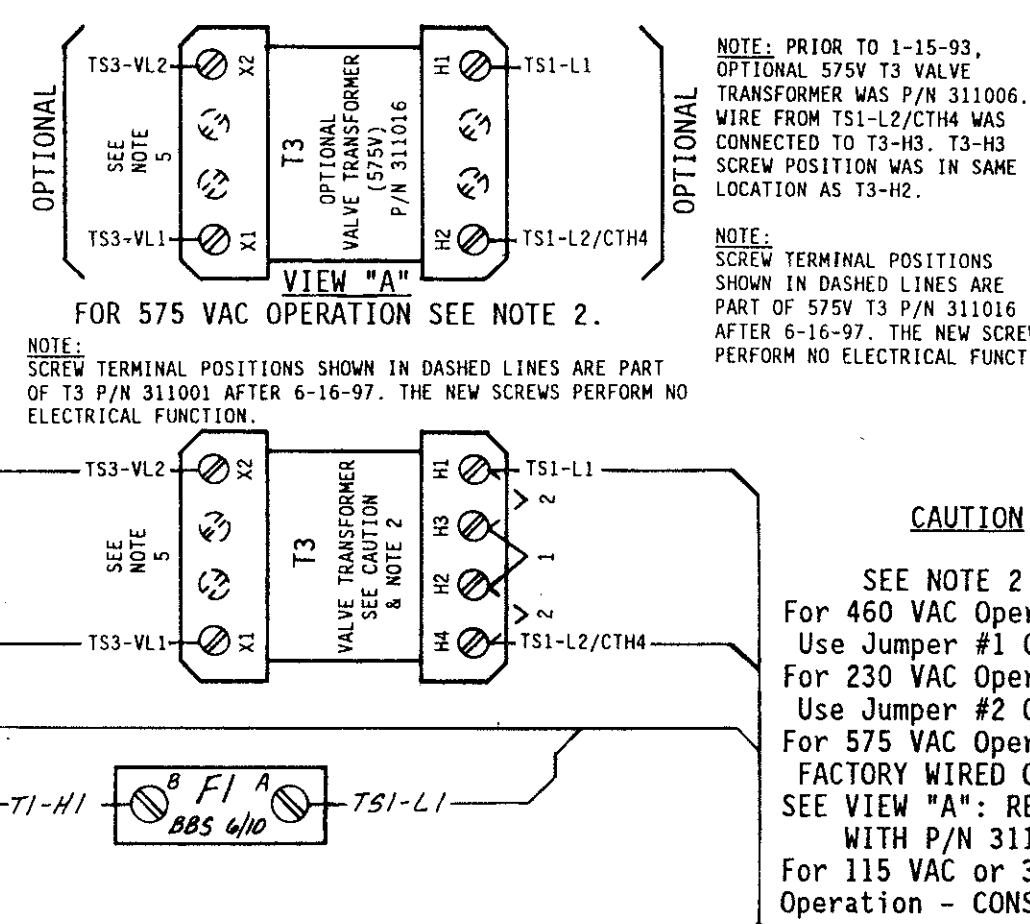

**CAUTION** Control Shipped Wired for 460 VAC Unless otherwise specified - See Note 2.

**CAUTION** DO NOT OPERATE WITHOUT WATER ON POWER ON WITHOUT WATER FLOW MAY CAUSE DAMAGE TO CONTROL. TURN POWER OFF WHEN CONTROL IS NOT IN USE.

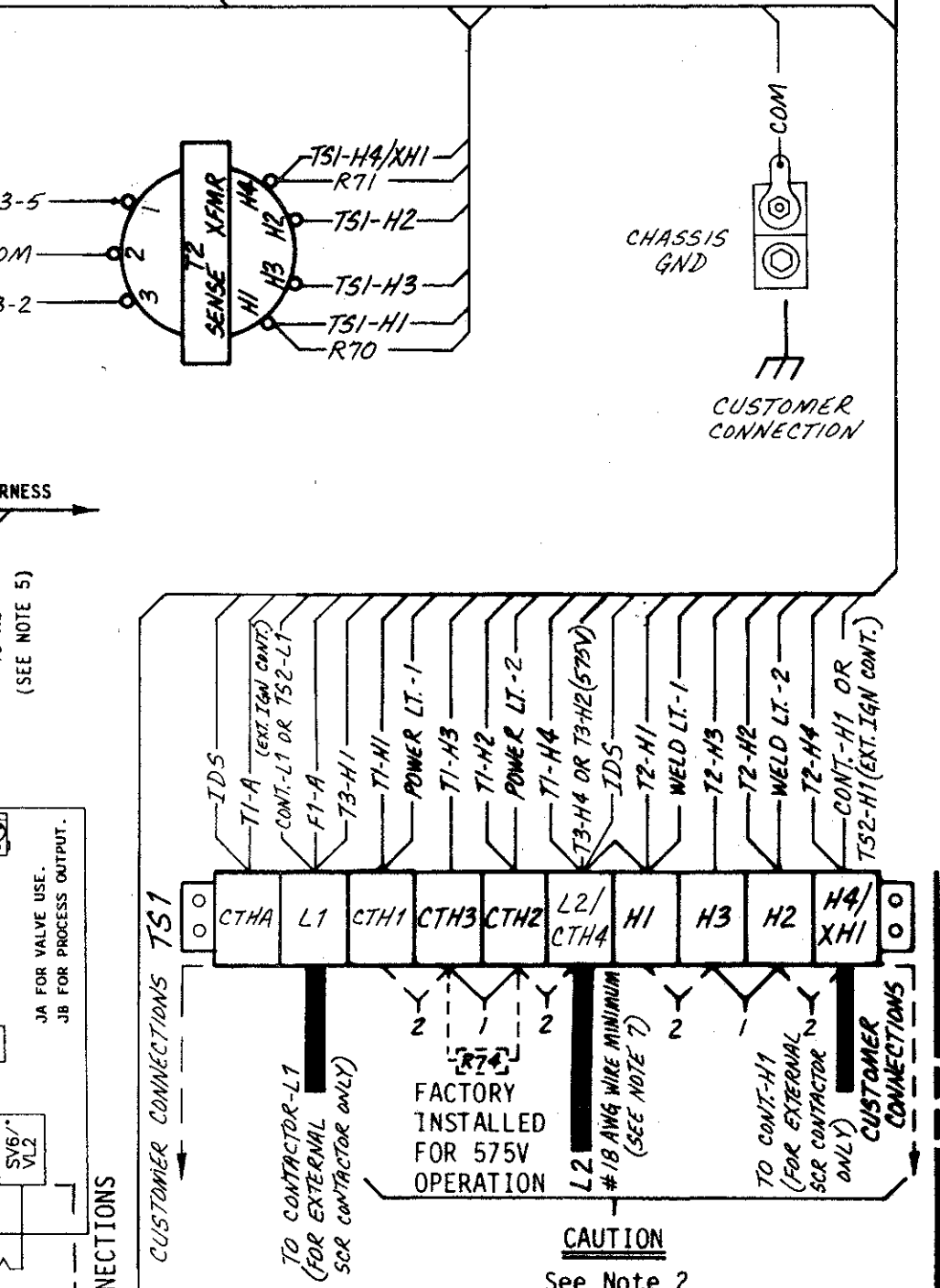
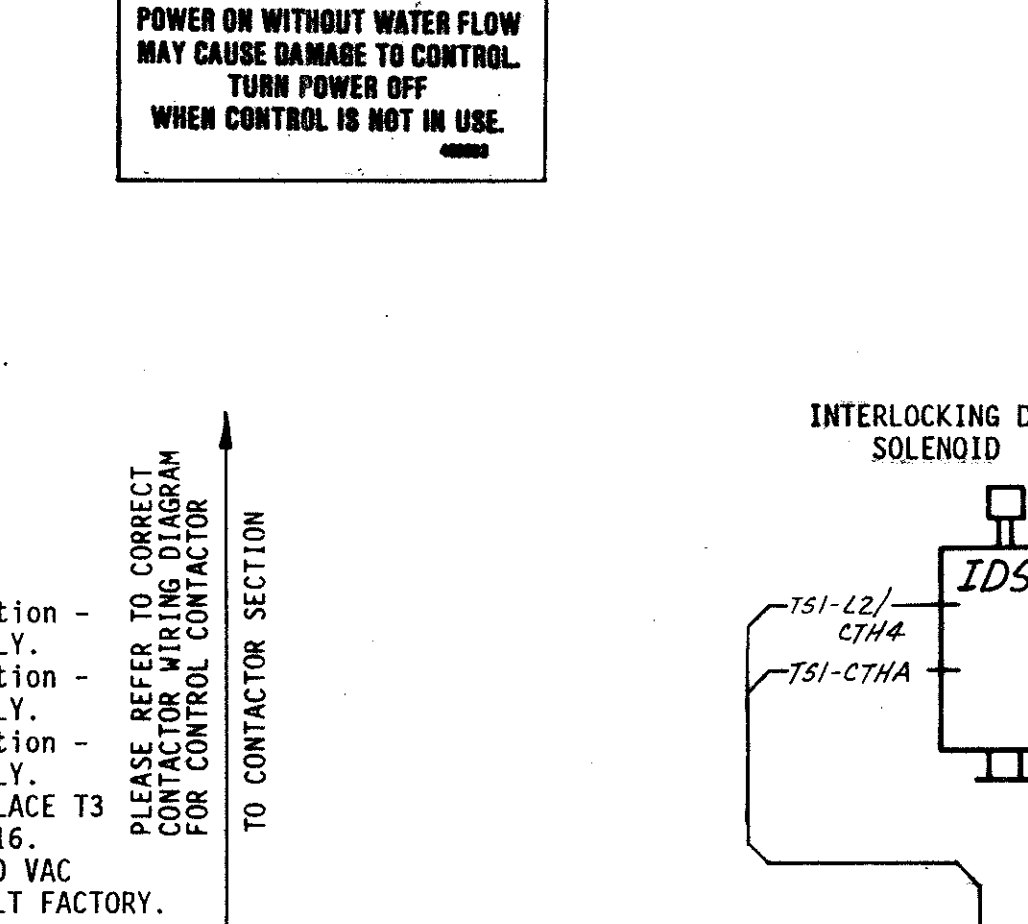

PARTS LIST - CONTROL SECTION			421382	
EXT. CONT.	QTY.	DESIG.	PART NO.	DESCRIPTION
1	1		600648	Assem., Dial Plate, EN1380, Consisting of:
0	1		600648-001	Assem., Dial Plate, w/Keylock, EN1380, Consisting of:
1	1	PCB1	600647	Assem., Switch, Sequence Control & Display Bd.
0	0	SW1	600531-001	Assem., Switch, Keylock, Momentary, SPST
1	1		540293	Illustrated Panel, Dial Plate, EN1380
1	1		515104	Panel, Display Window, Red Filter, EN1380
1	1		565003	Hole Plug, 3/8" Diam., Black
1	1		565013	Hole Plug, 3/8" Diam., Black, (For Rotary Bd. Hole)
X	X	PCB11	410350	Optional Assem., PCB, Rotary Input Board
X	X	J4-J4	319008	Knob, Skirted, w/o Indicator, Black
X	X		322447	Assem., Harness, Ctrl Bd. to Rotary Input Bd., 7" Lg.
1	1		305001	Lamp, Neon, Red, 230V
1	1		305002	Lamp, Neon, Clear, 230V
1	1	J2-J2	322303	Assem., Harness, Control Bd. to Terminal Bd.
1	1	J3	322304	Assem., Harness, Power, 150A & 300/600A Cont's
1	1	J3	322304-002	Assem., Harness, Power, External IGM Tube Cont's
1	1	J3	322304-003	Assem., Harness, Power, External SCR Contactors

PARTS LIST - CONTACTOR SECTION				
QTY.	DESIG.	PART NO.	DESCRIPTION	
1	T51	335034	Terminal Strip, 10 Pin, (Part of J3 Harness)	
1	T1	310001	Transformer, Control, (Part of J3 Harness)	
1	T2	310002	Transformer, Sense, (Part of J3 Harness)	
1	T3	311001	Transformer, Valve, 50VA	
*	T3	311016	Transformer, Valve, 50VA, 575V	
1	(J5-J5/J6-J6)	322311	Assem., Harness, IGM Firing Module to Term. Bd.	
2	R70,71	225016	Resistor, Power, Surge, 500 Ohm, 100W	
*	R72,73(PCB3)	220505	Resistor, Ignitor, 5 Ohm, 50W, (Part of 410318)	
*	R74	600048	Assem., Resistor, Power, 2000 Ohm, 10W, (For 575V)	
1	F1	308010	Fuseholder, 1 Pole, Mini, 600V	
1	F1	307018	Fuse, Control, 6/10A, BBS 6/10	
3	F6,7,8(PCB2)	307022	Fuse, 1 Amp, Slow Blow, 2AG, (Part of 410319 & 410319-001)	
1	F4,5(PCB3)	307010	Fuse, Ignitor, 6 Amp, BAF 6, (Part of 410318)	
1	(R70,71)	325191	Assem., Wire, Surge Resistor, 18 GA., Black	
2	(T3)	325149	Assem., Wire, Valve Transformer, 22 GA., Blk.	
1		600613	Assem., Contactor, Thyristor, Air, 150A, 460/575V, w/TLS	
1		600520	Assem., Cont., Thyristor, Air, 300A, 460/575V, w/TLS	
1		600609	Assem., Cont., Thyristor, Water, 600A, 460/575V	
1		300020	Switch, Temp. Limit, (Part of 600520 & 600613)	
2		346004	Lug, 5/16 Bolt to 2/O Wire, 600A Contactor, l1 & H1	
1		530021	Plate, Mounting, 600A Thyristor Contactor	
1		410319	Assem., PCB, Term. Strip Bd., EN1380	
1		410319-001	Assem., PCB, Term. Strip Bd., Ext. Firing, EN1380	
1		410318	Assem., PCB, IGM Firing Module	
1		510236	Plate, Mounting, Terminal Strip Board	
1		346004	Lug, Screw, Chassis GND, 2/O Wire	
1		600044	Assem., Interlocking Door Solenoid	
1		314001	Coil Assem Only, IDS	
1		510015	Cabinet, "S" Subcompact	
1		510017	Door, Cabinet, "S"	
1		700163	Manual, EN1380	
1		421383	Logic Diagram, EN1380 Control	
1		421382	Wiring Diagram, EN1380-Series, "S" Cabinet	

Optional Keylock when specified by customer. See Note 8. Pack key in Poly bag 900148 & attach to Door w/Yellow Tape 900118.

\* Substitution or Addition of Parts when 575V Control is specified.

X Optional. Add quantity one (1) PCB11 Rotary Input Board when specified by customer. Remove Hole Plug P/N 565013 when PCB11 is specified. Supply quantity one (1) each of J4-J4 Harness Assembly & Knob when optional PCB11 is specified.

See Drawings #600530, #600530-001, #600530-002, & #600530-003 for Mechanical Assembly Instructions.

See Drawing #440269 for Packing Instructions, "S" Cabinet.

See Drawing #440352 for Label Locations, "S" Cabinet.

See Drawing #440055 for Customer Mounting & Knockout Detail of "S" Cabinet.

See Drawing #600526 for Layout/Assembly of Front Panel.

Prior to 10-1-00 Fuse F1 was 6/10A Type BBS. After 10-1-00 Fuse F1 is 1/4A Type FNQ-R-1/4 or KLDK-1/4, ENTRON P/N 307024.

REV	AUTH	DESCRIPTION	DATE	CHK'D BY	DATE
1		ORIGINAL RELEASE			
2		DESCRIPTION			

**ENTRON CONTROLS INC.**

SCALE	DATE	DRAWN BY	CHK'D BY	APPROVED BY
10-1-98	Dec			

TOLERANCE UNLESS SPECIFIED	REV	DATE	TR	APPROVED BY
ANGLES: ± 1/2°				
DECIMALS: ± .010				
FRACTIONS: ± 1/64				

REV	AUTH	DESCRIPTION	DATE	CHK'D BY	DATE
1		WIRING DIAGRAM, EN1380-SERIES, "S" CABINET			

EN1380-S (IGN)  
EN1380-S (SCR)  
EN1380-150S  
EN1380-600S

REV. AUTH. DESCRIPTION DATE DATE

421382-