

ENTRON™

RT4jr. – REMOTE TERMINAL

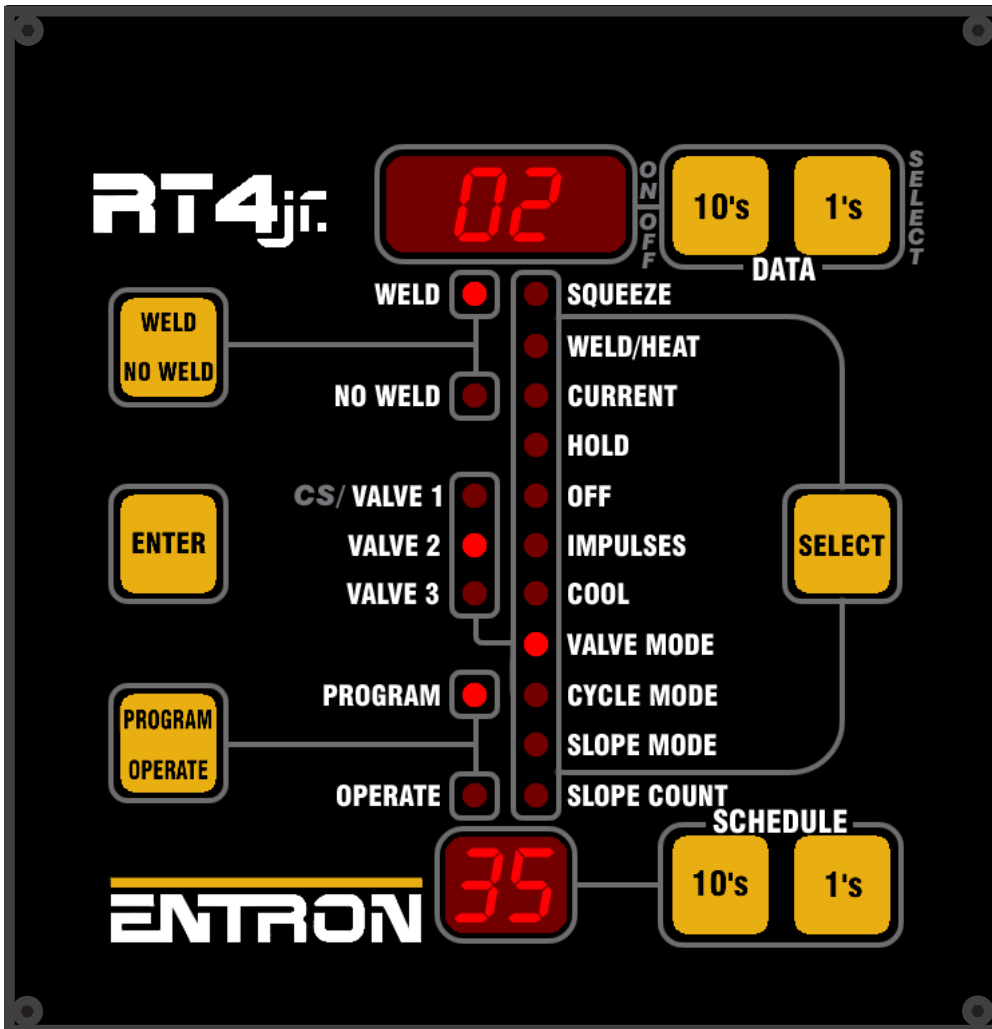

(Actual size)

- *Monitors from 1 to 64 Controls*
- *Long-Distance (up to 1 mile) Programming of Control Parameters*
- *Work Group Error Monitoring*
- *Work Group Current Monitoring*
- *Simple 2-wire 485 Interface*
- *Field Installable*
- *Complete with 25' of cable and two field-installable 9 pin D-subminiature connectors*
- *Laptop not needed to monitor or program*

Features

- Compact size
- Hand-held or machine mountable
- Distance from control up to 1 mile
- Remote data entry
- Scan work group (subset) of 64 controls for errors
- Use when RDEjr. pendant cable length is too short for application
- Has its own programmable PIN# which overrides control PIN# when used

Requirements

- 485 Option on Weld Controls
- 2-wire network between components of network
- 24 VDC power



Exclusive ENTRON two year warranty

Available Models

- EN1000
- EN1001
- EN1000 Cascade
- EN1001 Cascade

RT4jr. dimensions

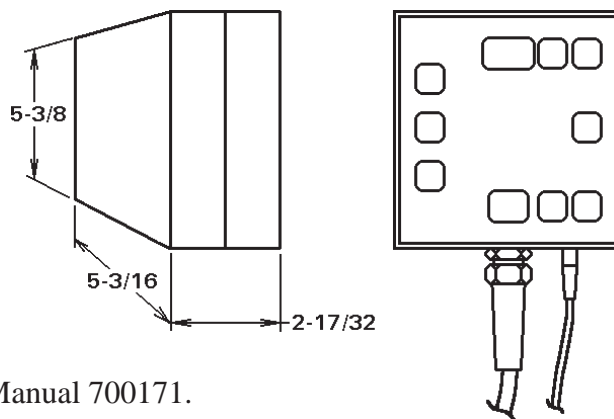

For more technical information, see Instruction Manual 700171.

RT4jr. is part of a complete networking system



Distributed by:

ENTRON™

ENTRON Controls, LLC.
1402 S. Batesville Road
Greer, SC 29650
(864) 416-0190
FAX (864) 416-0195
www.entroncontrols.com
e-mail: info@entroncontrols.com

RWMA®
MEMBER

780085-0414